

## Vectors and Projectiles

1. Equations to know:

$$(1) A_y = A \sin \theta$$

$$(2) A_x = A \cos \theta$$

2. Terms to know:

vector, magnitude, direction, resultant, component, equilibrium, equilibrant, concurrent forces, trajectory, projectile

3. Read Chapter 3.

You should be able to . . .

4. draw a vector to scale with a protractor and ruler.

5. add two vectors together to scale, draw the resultant, and measure the resultant's magnitude and direction.

6. know how to add vectors to obtain a maximum and a minimum value.

7. determine the angle between two vectors, especially for maximum and minimum values. (NOTE: This is not the same as the angle for the direction of the resultant.)

8. find the components of a resultant vector using a ruler and protractor.

9. add two vectors to find the resultant vector's magnitude and direction using the Pythagorean Theorem and trigonometry.

10. determine the components of a resultant vector using trigonometry.

11. find the resultant force vector from two concurrent force vectors.

12. identify forces that are in equilibrium and find the equilibrant vector.

13. A ball is launched horizontally off a building. At the same time, a ball is dropped off the building. For the two balls, compare:

- the time taken to reach the ground **Both hit at the same time**
- initial velocities in the x and y directions  **$V_i$  in y direction = 0 for both, in x = 0 for dropped ball. Launched ball  $V_i$  = some value.**
- the acceleration  **$a = -9.81 \text{ m/s}^2$  for both balls**
- the displacements in the x and y directions.  **$d_y$  is same for both,  $d_x = 0$  for dropped,  $d_x$  = some value for launched.**

14. A soccer ball is kicked with an initial velocity of 15 m/s at an angle of  $30^\circ$  above the horizontal. Describe what happens to the vertical and horizontal components of its velocity as the soccer ball flies through the air and lands.

**Vertical velocity decreases until it hits top of path and then increases as heads back down.  
Horizontal velocity remains the same (no horizontal acceleration)**

15. Draw the resultant and equillibrant of the following concurrent vectors.

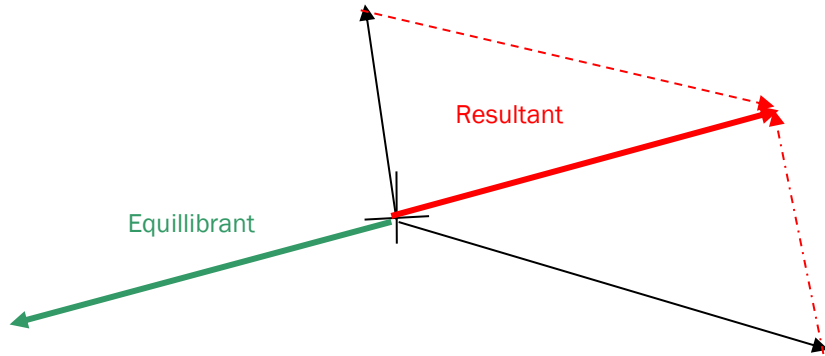

16. Draw in the resultant for the following vectors. **Label** your resultant. Make sure it has an arrow head.

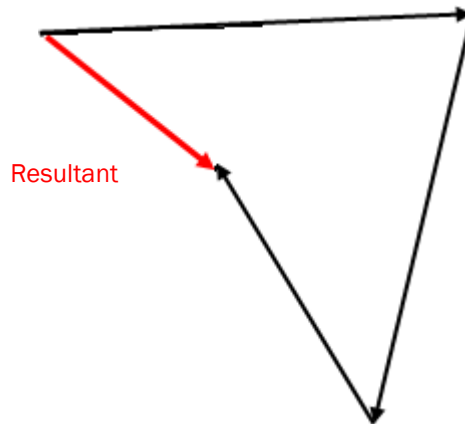

17. Measure the magnitude and direction (that means angle and a compass direction) of the following vectors using the given scales.

- o 1 cm = 852 km/hr

$$2.94 \text{ cm} \left( \frac{852 \text{ km/hr}}{1 \text{ cm}} \right) = 2510 \text{ km/hr @ } 50.0^\circ \text{ N of E}$$

$$\pm .20 \text{ cm} = \pm 170 \text{ km/hr (2340 - 2680 km/h)}$$

$$\pm 2^\circ = 48.0^\circ - 52.0^\circ$$

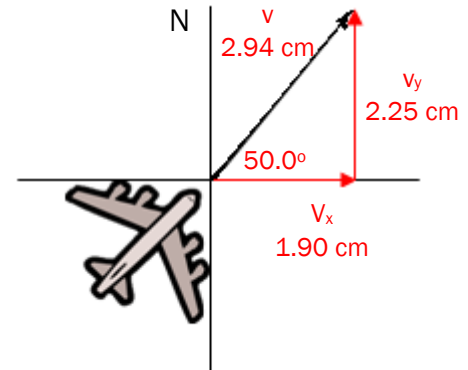

18. For the diagram use the both the mathematical and scale method to break the resultants into horizontal (x) and vertical (y) components.

**Scale:**

Horizontal: 1.90 cm (852 km/hr/1 cm)  
 1.70 cm - 2.10 cm = 1620 km/hr East  
 (1450 km/hr - 1790 km/hr)

Vertical: 2.25 cm (852 km/hr/1 cm)  
 2.05 cm - 2.45 cm = 1920 km/hr North  
 (1750 km/hr - 2090 km/hr)

**Mathematical:**

Horizontal:  $v_x = v \cos \theta$   
 $= (2510 \text{ km/hr})(\cos 50.0^\circ)$   
 $= 1610 \text{ km/hr East}$

Vertical:  $v_y = v \sin \theta$   
 $= 2510 \text{ km/hr}(\sin 50.0^\circ)$   
 $= 1920 \text{ km/hr North}$

Directions: Read each question carefully and record your answers in the space provided. Be sure to show all work! Answers should be in significant figures. You will be graded on proper use of the GUESS method. **These will be the same directions on the test. Practice the GUESS method now.**

19. A student pulls a cart across a horizontal floor by exerting a force of 50. N at a 40.° angle above the horizon.

**The line should be 5.0 cm long and extend from either a corner of the cart.**

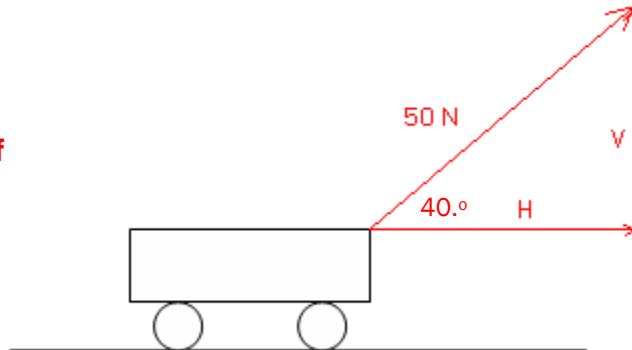

- On the diagram construct a scaled vector showing the 50 N force at the correct angle. Use a scale of 1 cm = 10 N. Label the force and angle.
- Construct the horizontal and vertical components to scale. Label the horizontal force H and the vertical force V.
- What is the magnitude of the vertical component of the force?

$$F_y = F \sin \theta = (50\text{N}) \sin 40 = 32\text{N}$$

- What is the magnitude of the horizontal component of the force?

$$F_x = F \cos \theta = (50\text{N}) \cos 40 = 38\text{N}$$

20. A plane is flying at 280. m/s at 28.0° North of West while the wind is blowing at 72 m/s at 12° North of East. Determine the resultant velocity of the airplane using the mathematical method.

1. Break vector into components.

$$v_{1x} = 280. \text{ m/s} (\cos 28.0^\circ) = 247 \text{ m/s West}$$

$$v_{1y} = 280. \text{ m/s} (\sin 28.0^\circ) = 131 \text{ m/s North}$$

$$v_{2x} = 72 \text{ m/s} (\cos 12^\circ) = 70. \text{ m/s East}$$

$$v_{2y} = 72 \text{ m/s} (\sin 12^\circ) = 15 \text{ m/s North}$$

2. Sum of x and y components

$$v_{\text{net}x} = v_{1x} + v_{2x} = (-247 \text{ m/s}) + (70. \text{ m/s}) = 177 \text{ m/s West}$$

$$v_{\text{net}y} = v_{1y} + v_{2y} = (131 \text{ m/s}) + (15 \text{ m/s}) = 146 \text{ m/s North}$$

3. Magnitude of net velocity

$$v_{\text{net}} = \sqrt{v_x^2 + v_y^2} = \sqrt{(177 \frac{\text{m}}{\text{s}})^2 + (146 \frac{\text{m}}{\text{s}})^2} = 229 \text{ m/s}$$

4. Find the angle (gives you direction)

$$\theta = \tan^{-1} (O/A)$$

$$= \tan^{-1} (146 \text{ m/s} / 177 \text{ m/s})$$

$$= 39.5^\circ \text{ North of West}$$

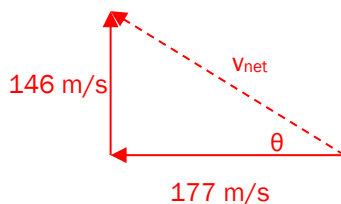

229 m/s at 39.5° North of West  
OR  
229 m/s at 140.5°

21. A player kicks a football from ground level at 27 m/s at an angle of 35° above the horizontal. Calculate the following.

a. the x and y components of the initial velocity.

Degree mode!	$v_{iy} = v_i \sin \theta = 27 \frac{m}{s} (\sin 35^\circ) = 15 \frac{m}{s} \text{ up}$ $v_{ix} = v_i \cos \theta = 27 \frac{m}{s} (\cos 35^\circ) = 22 \frac{m}{s} \text{ forward}$
--------------	--------------------------------------------------------------------------------------------------------------------------------------------------------------------------------------

b. the total time the ball is in the air.

y info $v = 0 \text{ m/s}$ at top total is double top	$t_{top} = \frac{v_f - v_i}{a} = \frac{-15 \frac{m}{s}}{-9.81 \frac{m}{s^2}} = 1.5s$ $t_{total} = 2(t_{top}) = 2(1.5s) = 3.0s$
-------------------------------------------------------------	--------------------------------------------------------------------------------------------------------------------------------

c. the distance the ball travels (horizontally) before it hits the ground.

x info use total time	$d_x = v_x t_{total} = 22 \frac{m}{s} (3.0s) = 66m$
--------------------------	-----------------------------------------------------

d. its maximum height.

y info use time to top	$d_y = v_{iy} t_{top} + \frac{1}{2} a t_{top}^2 = (15 \frac{m}{s})(1.5s) + \frac{1}{2} (-9.81 \frac{m}{s^2})(1.5s)^2 = 11m$
---------------------------	-----------------------------------------------------------------------------------------------------------------------------

22. A ball is rolled down a ramp and projected horizontally from a height of 1.7 meters. It lands 2.6 meters away. Calculate its initial speed. [Note: This is similar to the Shoot for Your Grade Lab]

**Step 1 - Solve for time using the height** 
$$t = \sqrt{\frac{2d_y}{g}} = \sqrt{\frac{2(1.7m)}{-9.81 \frac{m}{s^2}}} = 0.59s$$

**Step 2 - Use the time and x distance to solve for  $v_x$**  
$$v_{ix} = \frac{d_x}{t} = \frac{2.6m}{0.59s} = 4.4 \frac{m}{s}$$

23. The ball from question 22 is now raised to a height of 2.4 meters. Where is it going to land? [Hint: The initial velocity does not change with a height change.]

**Step 1 - Solve for new time using the new height** 
$$t = \sqrt{\frac{2d_y}{g}} = \sqrt{\frac{2(2.4m)}{-9.81 \frac{m}{s^2}}} = 0.70s$$

**Step 2 - Use the new time and  $v_x$  from #22 to solve for  $d_x$**

$$d = v_x t = 4.4 \frac{m}{s} (0.70s) = 3.1m$$

24. In the diagram below, a force,  $F$ , is applied to the handle of a lawnmower inclined at angle  $\theta$  to the ground.



The magnitude of the horizontal component of force  $F$  depends on

$$F_x = F \cdot \cos\theta$$

- (A) the magnitude of force  $F$ , only
- (B) neither the magnitude of force  $F$  nor the measure of angle  $\theta$
- (C) the measure of angle  $\theta$ , only
- (D) both the magnitude of force  $F$  and the measure of angle  $\theta$

25. Forces A and B have a resultant R. Force A and resultant R are represented in the diagram below.

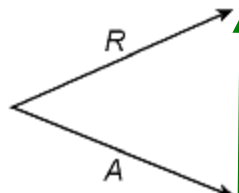

Components add head to tail  
Resultants are start to finish

Which vector *best* represents force B?

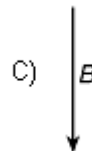
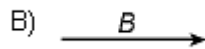
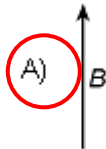

26. A river flows due east at 1.5 meters per second. A motorboat leaves the north shore of the river and heads due south at 2.0 meters per second, as shown in the diagram below.

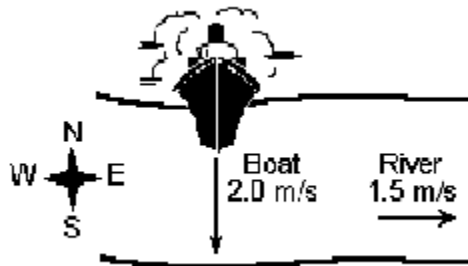

$$v = \sqrt{v_x^2 + v_y^2} = \sqrt{(1.5 \frac{m}{s})^2 + (2.0 \frac{m}{s})^2}$$

Which vector *best* represents the resultant velocity of the boat relative to the riverbank?

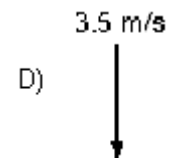
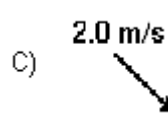
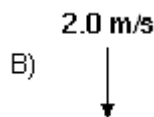
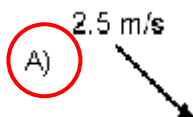

27. The vector below represents the resultant of two forces acting concurrently on an object at point P.



Which pair of vectors best represent two concurrent forces that combine to produce this resultant force vector? Redraw them head to tail

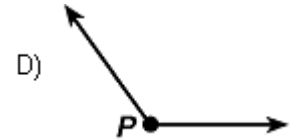
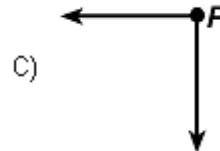
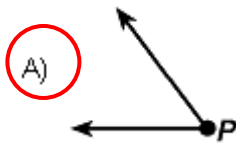

28. As the angle between a force and level ground decreases from  $60^\circ$  to  $30^\circ$ , the vertical component of the force

- (A) increases      (B) decreases      (C) remains the same

Lower angles are more horizontal, less vertical

29. Into how many possible components can a single force be resolved?

- (A) two      (B) three      (C) four      (D) unlimited number

Unlimited ways to get from A to B, we just choose 2 to make math easier

Questions 30 and 31 refer to the following:

Projectile A is launched horizontally at a speed of 20. meters per second from the top of a cliff and strikes a level surface below, 3.0 seconds later. Projectile B is launched horizontally from the same location at a speed of 30. meters per second.

Same height means same time, horizontal speed doesn't affect vertical motion

30. How much time does it take projectile B to reach the level surface?

- (A) 10. s      (B) 4.5 s      (C) 3.0 s      (D) 2.0 s

31. Approximately how high is the cliff?  $d = v_i t + \frac{1}{2} a t^2 = \frac{1}{2} (-9.81 \frac{m}{s^2}) (3.0s)^2$

- (A) 29 m      (B) 44 m      (C) 60. M      (D) 104 m

32. A ball is thrown at an angle of  $38^\circ$  to the horizontal. What happens to the magnitude of the ball's vertical acceleration during the total time interval that the ball is in the air?

- (A) It increases, then decreases.  
 (B) It decreases, then increases.  
 (C) It decreases, then remains the same  
 (D) It remains the same

GRAVITY!

33. A football player kicks a ball with an initial velocity of 25 meters per second at an angle of  $53^\circ$  above the horizontal. What is the vertical component the initial velocity of the ball?

- (A) 20. m/s      (B) 25 m/s      (C) 15 m/s      (D) 10. m/s

$v_y = v \sin \theta = (25 \frac{m}{s}) \sin 53^\circ$

Questions 34 through 36 refer to the following:

A ball is thrown horizontally with an initial velocity of 20.0 meters per second from the top of a tower 60.0 meters high, as shown in the diagram below.

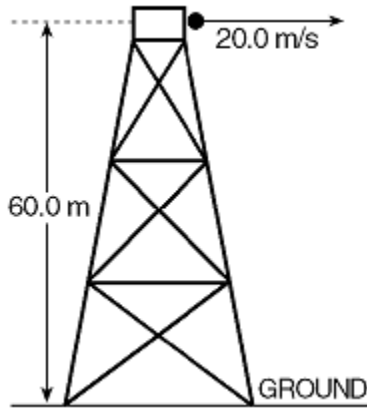

Horizontal speed stays the same

34. What is the horizontal velocity of the ball just before it reaches the ground?  
 (A) 20. m/s                      (B) 9.81 m/s                      (C) 34.3 m/s                      (D) 68.6 m/s

35. What is the approximate total time required for the ball to reach the ground?  
 (A) 2.04 s                      (B) 3.00 s                      (C) 3.50 s                      (D) 12.2 s

$$t = \sqrt{\frac{2d}{a}} = \sqrt{\frac{2(60.0m)}{-9.81 \frac{m}{s^2}}}$$

36. What is the initial vertical velocity of the ball?  
 (A) 60.0 m/s                      (B) 20.0 m/s                      (C) 9.81 m/s

All of the initial speed is horizontal  
 (D) 0 m/s

37. The diagram below shows a student throwing a baseball horizontally at 25 meters per second from a cliff 45 meters above level ground.

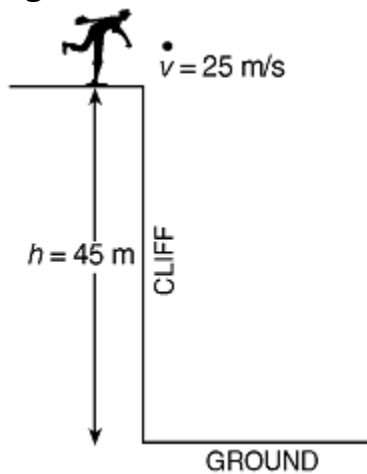

Two steps - solve for t first

$$t = \sqrt{\frac{2d}{a}} = \sqrt{\frac{2(45m)}{-9.81 \frac{m}{s^2}}} = 3.0s$$

$$d_x = v_x t = (25 \frac{m}{s})(3.0s)$$

Approximately how far from the base of the cliff does the ball hit the ground? [Neglect air resistance]

- (A) 45 m                      (B) 75 m                      (C) 140 m                      (D) 230 m

38. A book is pushed with an initial horizontal velocity of 5.0 meters per second off the top of a desk. What is the initial vertical velocity of the book?

- (A) 5.0 m/s                      (B) 10 m/s                      (C) 2.5 m/s                      (D) 0 m/s

All of the initial speed is horizontal

39. Which graph best represents the motion of an object whose speed is increasing?

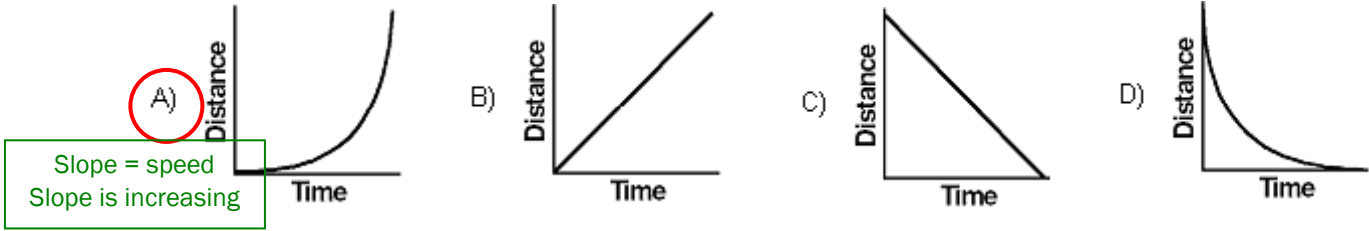

A) Slope = speed  
Slope is increasing

40. A projectile is launched with an initial velocity of 200 meters per second at an angle of  $30^\circ$  above the horizontal. What is the magnitude of the vertical component of the projectile's initial velocity?

$$v_{iy} = v_i \sin \theta$$

(A)  $200 \frac{m}{s} \times \sin 30^\circ$

(C)  $200 \frac{m}{s} \times \cos 30^\circ$

(B)  $\frac{200m/s}{\sin 30^\circ}$

(D)  $\frac{200m/s}{\cos 30^\circ}$

Question 41 and 42 refer to the following:

A golf ball leaves a golf club with an initial velocity of 40.0 meters per second at an angle of  $40.0^\circ$  with the horizontal.

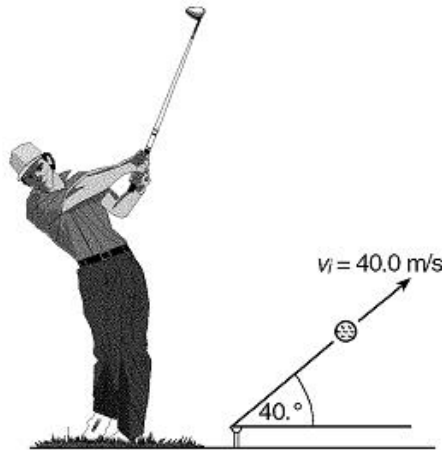

$$v_{iy} = v_i \sin \theta = (40.0 \frac{m}{s})(\sin 40.0^\circ)$$

41. What is the vertical component of the golf ball's initial velocity?

(A) 25.7 m/s

(B) 40.0 m/s

(C) 30.6 m/s

(D) 61.3 m/s

42. What is the total horizontal distance traveled by the golf ball during the first 2.50 seconds of flight?

(A) 40.0 m

(B) 64.3 m

(C) 76.6 m

(D) 100. m

Two steps - solve for  $v_{ix}$  first  
 $v_{ix} = v_i \cos \theta = (40.0 \frac{m}{s}) \cos 40.0^\circ = 30.6 \frac{m}{s}$   
 $d_x = v_{ix} t = (30.6 \frac{m}{s})(2.50s)$

- 42. C
- 41. A
- 40. A
- 39. A
- 38. D
- 37. D
- 36. D
- 35. C
- 34. A
- 33. A
- 32. D
- 31. B
- 30. C
- 29. D
- 28. B
- 27. A
- 26. A
- 25. A
- 24. D
- 23. 3.1 m
- 22. 4.4 m/s
- 21. d. 11 m
- 20. 229 m/s at  $39.5^\circ$  N of W
- 19.  $v_x = 22 \text{ m/s}$
- 18.  $v_y = 15 \text{ m/s}$
- 17. 3.0 s
- 16. 66 m
- 15. 11 m

Name \_\_\_\_\_ Answer Key \_\_\_\_\_

Date \_\_\_\_\_

Answers:

For questions #13 - 19 see sheets posted in the classroom



### SAT Review: Vectors & Projectiles

Unless otherwise noted, use  $g = 10 \text{ m/s}^2$  and neglect air resistance for all questions.

#### PART A

Directions – For each group of questions below, there is a set of five letter choices, followed by numbered questions. For each question select the one choice in the set that best answers the question. You may use a lettered choice once, more than once, or not at all in each set. Do not use a calculator or table of reference.

Questions 1 – 3 relate to the diagram below and the choices that follow.



A projectile is launched at an angle from level ground. Assume air resistance is negligible.

- (A) horizontal velocity
  - (B) vertical velocity
  - (C) horizontal acceleration
  - (D) vertical acceleration
  - (E) angle at which projectile is launched
1. Which of the following choices is NOT constant throughout the flight of the projectile? **B**
  2. Which of the above choices is zero throughout the flight of the projectile? **C**
  3. Which of the above choices changes direction during the flight of the projectile? **B**

#### PART B

Directions – Each of the questions or incomplete statements below is followed by five answer choices. Select the choice that best answers the question or completes the statement. Do not use a calculator or any tables of reference.

4. Which of the following quantities is NOT a vector quantity?
  - A) displacement
  - B) 10 km at  $30^\circ$  north of east
  - C) resultant
  - D) equilibrant
  - E) **mass**

5. The resultant of two displacement vectors 3 m east and 4 m north is
  - A) **5 m northeast**
  - B) 7 m northeast
  - C) 1 m southwest
  - D) 1 m northeast
  - E) 12 m northeast

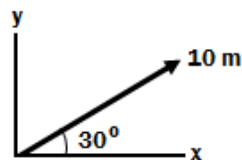

6. The x-component of the vector shown is most nearly ( $\sin 30^\circ = 0.5$ ,  $\cos 30^\circ = 0.87$ )
  - A) 10 m.
  - B) 5 m.
  - C) 5.8 m.
  - D) **8.7 m.**
  - E) 100 m.
7. A projectile is launched horizontally from the edge of a cliff 20 m high with an initial speed of 10 m/s. What is the horizontal distance the projectile travels before striking the ground?
  - A) 5 m
  - B) 10 m
  - C) **20 m**
  - D) 40 m
  - E) 60 m

8. A projectile is launched from level ground with a velocity of 40 m/s at an angle of  $30^\circ$  from the ground. What will be the vertical component of the projectile's velocity just before it strikes the ground? ( $\sin 30^\circ = 0.5$ ,  $\cos 30^\circ = 0.87$ )
  - A) 10 m/s
  - B) **20 m/s**
  - C) 30 m/s
  - D) 35 m/s
  - E) 40 m/s

Questions 9 – 10 relate to the following.

A steel sphere is launched horizontally with a speed  $v$  from the edge of a table of height  $h$  above a level floor. At the same instant, another steel sphere is dropped from the edge of the same table. Air resistance may be neglected.

9. Which of the following statements is true?

- A) The two spheres will strike the floor at the same time.
- B) The sphere that is dropped will strike the floor first.
- C) The sphere that is launched horizontally will strike the floor first.
- D) The acceleration of the sphere that is dropped is greater than the acceleration of the other sphere after it is launched.
- E) The acceleration of the sphere after it is launched is greater than the acceleration of the sphere that is dropped.

10. If the mass of the sphere that is dropped is doubled, and the mass of the launched sphere remains the same, which of the following is true?

- A) The two spheres will strike the floor at the same time.
- B) The sphere that is dropped will strike the floor first.
- C) The sphere that is launched horizontally will strike the floor first.
- D) The acceleration of the sphere that is dropped is greater than the acceleration of the other sphere after it is launched.
- E) The acceleration of the sphere after it is launched is greater than the acceleration of the sphere that is dropped.

Answers: 1) B, 2) C, 3) B, 4) E, 5) A, 6) D, 7) C, 8) B, 9) A, 10) A